

Rittal – The System.

Faster – better – everywhere.



Schaltschrank-Heizung
Enclosure heater
Résistances chauffantes
Schackelkastverwarmingen
Värmeelement för apparatskåp
Riscaldatore anticondensa
Resistencia calefactora
エンクロージャー用ヒーター

3105.XXX

Montage-, Installations- und Bedienungsanleitung
Assembly and operating instructions
Manuel d'installation et de maintenance
Montage- en bedieningshandleiding
Montage- och hanteringsanvisning
Istruzioni di montaggio e funzionamento
Instrucciones de montaje
取扱説明書

ENCLOSURES

POWER DISTRIBUTION

CLIMATE CONTROL

IT INFRASTRUCTURE

SOFTWARE & SERVICES



Contents

1	Notes on documentation	3
1.1	Other applicable documents . . .	3
1.2	CE certification	3
1.3	Storing the documents	3
1.4	Symbols used	3
2	Safety notes	3
3	Device description	4
3.1	Functional description	4
3.1.1	How it works	4
3.1.2	Control	4
3.2	Proper use	4
3.3	Scope of supply	4
4	Mounting	5
5	Electrical connection	5
6	Storage and disposal	6
7	Warranty	6
8	Technical specifications	6
9	Dimensions	7

1 Notes on documentation

1 Notes on documentation

These assembly instructions are aimed at

- tradespersons who are familiar with assembly and installation of the heater
- trained specialists who are familiar with operation of the heater

1.1 Other applicable documents

Assembly and operating instructions exist as paper documents for the unit types described here and are enclosed with the equipment.

We cannot accept any liability for damage associated with failure to observe these instructions. Where applicable, the instructions for any accessories used also apply.

1.2 CE certification

The declaration of conformity is supplied with the unit as a separate document.

1.3 Retention of documents

These instructions and all associated documents constitute an integral part of the product. They must be given to the plant operator. The operator is responsible for storage of the documents so they are readily available when needed.

1.4 Symbols used

- **The bullet point indicates an action to be performed.**



Danger!
Immediate danger to life and limb!



Caution!
Potential threat to the product and its environment.



Note:
Useful information and special features.

2 Safety notes

- When performing the electrical installation, it is important to observe all valid national and regional regulations as well as the provisions of the responsible electrical supply company.
- Electrical installation must only be carried out by a qualified electrician who is responsible for compliance with the existing standards and regulations.
- Use only original spare parts!
- The heater must not be touched while switched on. Risk of burns from hot surfaces! The heater must be allowed to cool for approx. 15 minutes after switching off.



Caution!
Risk of burns from hot surfaces!

3 Device description

EN

3 Device description

Depending on the model chosen, your heater may vary in appearance from the illustrations contained in these instructions.

However, the functions are identical in principle.

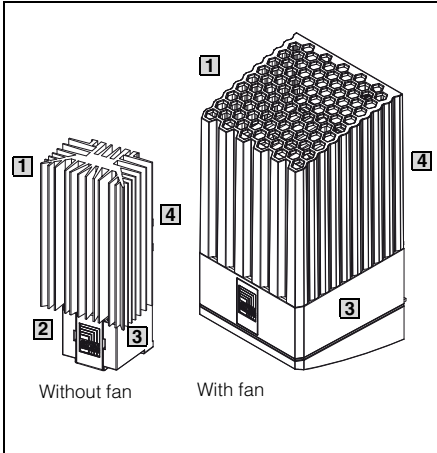

Fig. 1: Device description

Key

- 1 Aluminium section (without fan) or heater housing (with fan)
- 2 Protective cover for electrical connection
- 3 Base plate
- 4 Fixing points

3.1 Functional description

Heaters are used to prevent the formation of condensation inside the enclosure and maintain a constant minimum operating temperature (e.g. when the system is switched off overnight).

Rittal heaters achieve thermal outputs of 8 to 870 watts.

3.1.1 How it works

The heaters are comprised of the following main components:

Heaters without fan

- Aluminium section
- PTC heater element

Heaters with fan

- PTC heat register
- Fan

3.1.2 Control

A separate thermostat (3110.000) or a digital thermostat (3114.200) must be used to control the enclosure temperature. The humidity of the air in the enclosure can be controlled by incorporating a hygrostat (3118.000).

3.2 Proper use

Rittal heaters were developed and designed in accordance with the state of the art and the recognised rules governing technical safety. Nevertheless, if used improperly, they may pose a threat to life and limb or cause damage to property. The heater is designed to heat closed enclosures that are only accessible by trained specialists. The admissible temperature range is -33°C to +65°C. The manufacturer will not be liable for any damages caused as a result of improper use, or for incorrect assembly, installation or use. All risk is borne solely by the user.

3.3 Scope of supply

The heater is supplied in one packaging unit.

Model No.	Qty.	Designation
3105.310 – .370	1	Base plate
	1	Aluminium section
	1	Cover cap
	1	Assembly instructions
		Assembly parts (see fig. 2)
3105.380 – .430	1	Heater (pre-assembled)
	1	Assembly instructions
		Assembly parts (see fig. 2)

Tab. 1: Scope of supply

4 Mounting

The heater is fitted vertically, i.e. with the connection terminal or fan facing downwards. To permit the required convection, a minimum clearance to the adjacent components must be observed. A safety clearance of at least 300 mm must be left at the air outlet in the case of heaters with fans, and 100 mm for heaters without fans. (For both heaters a thermal safety clearance to the sides of 60 mm and 100 mm at the bottom is required). If these clearances are observed, the ambient temperature at the air inlet does not rise above 65°C.

There are two different methods of assembling the heater:

1. Snap-type fastening onto a 35 mm support rail DIN EN 50 022 (fig. 2).
2. Screw fastening onto the mounting plate (fig. 3).

It should be ensured that the heater and connection cables are mounted firmly and securely.

Electric cables must not touch the body of the heater fan and must not be routed directly past the hot air outlet.

The heater must not be mounted in the vicinity of flammable materials.



Note:

In justified, exceptional cases, heaters with fan (235 – 870 W) may be installed rotated through 180°.

Please note that, in case of mounting on a 35 mm support rail, the mounting clips must also be rotated through 180°.

5 Electrical connection

The heater must be connected, via the quick-connect terminals, to a power supply of the voltage stated on the rating plate.

The heater must be connected to the mains via an all-pole isolating device in accordance with the overvoltage category III to EN 60 664-1. Only copper wires are to be used for the electrical connection. Due to the special characteristics of the PTC heater element, a current of up to 4.4 A may be reached for a short time when the heater is switched on.

Slow-blowing fuse-links (gG) or circuit-breakers with a corresponding delayed-trip characteristic can be used as pre-fuses. The required pre-fuse rating is specified on the rating plate. Overvoltage protection is to be provided where pulse loads exceeding 1,000 V are possible. The double connection terminal permits the cascading of several heaters and thus simplifies wiring. In such cases, it may be necessary to adapt the pre-fuse rating to accommodate the total start-up current. The maximum switching capacity of the devices must nevertheless be observed.

6 Storage and disposal

EN

6 Storage and disposal



Caution!
Risk of damage!
The heater must not be stored at temperatures above +65°C or below -33°C.

Disposal can be performed at the Rittal plant. Please contact us for advice.

7 Warranty

This unit is covered by a 1-year guarantee from the date of supply, subject to correct usage. Within this period, the returned unit will be repaired in the factory or replaced free of charge.

Unauthorised utilisation or incorrect connection will invalidate the manufacturer's guarantee. No liability will be assumed for any damage arising from such situations.

8 Technical specifications

Heaters without fan

Model No.	3105.310	3105.320	3105.330	3105.340	3105.350	3105.360	3105.370
Dimensions in mm	W	45	45	64	64	64	90
	H	120	120	155	155	230	165
	D	46	46	56	56	56	75
Hole distance A mm	42					60	
Rated operating voltage	110 – 240 V AC, 50/60 Hz, 110 – 240 V DC						
Continuous thermal output W at T_u = 10°C	8 – 10	18 – 20	23 – 30	49 – 50	63 – 75	86 – 100	130 – 150
Ambient temperature	-33°C...+65°C						
Pre-fuse T	2 A			4 A			
Protection category	IP 20						
Protection class	II						

We reserve the right to make technical modifications.

Heaters with fan

Model No.	3105.380	3105.390	3105.400	3105.410	3105.420	3105.430
Dimensions in mm	W	103				
	H	200				
	D	103				
Hole distance A mm	171					
Hole distance B mm	153 (fitted rotated through 180°)					
Rated operating voltage	230 V, 50/60 Hz			115 V, 50/60 Hz		
Continuous thermal output W at T_u = 10°C	250/265	400/415	800/870	235/250	355/400	710/800
Ambient temperature	-33°C...+65°C					
Pre-fuse gG f	4 A	6 A	6 A	4 A	6 A	10 A
Protection category	IP 20					
Protection class	II					

We reserve the right to make technical modifications.

9 Dimensions

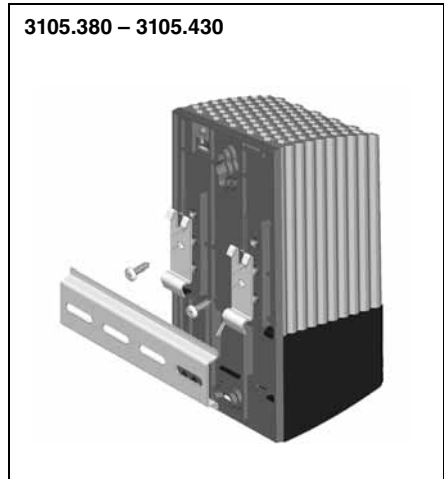
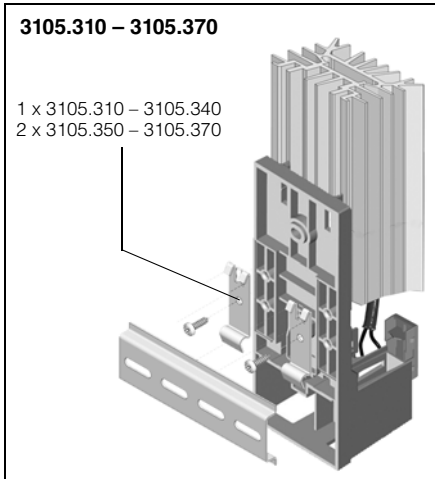

Fig. 2: Snap-type fastening onto a 35 mm support rail DIN EN 50 022

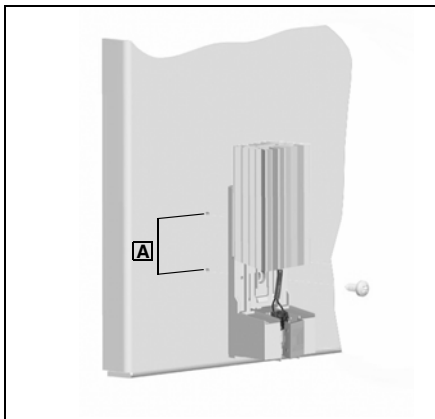
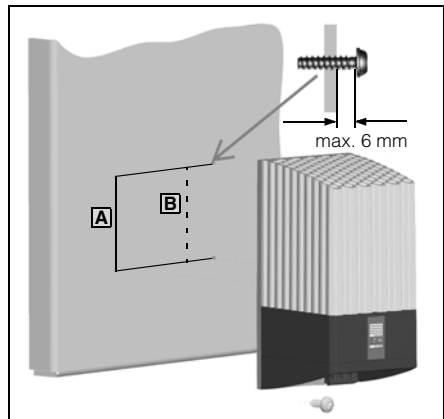

Fig. 3: Screw fastening onto a mounting plate



- A** Hole distance
- B** Hole distance for fitting rotated through 180°



Note:

In case of assembly rotated through 180°, the mounting clips must always point upwards.

9 Dimensions

EN

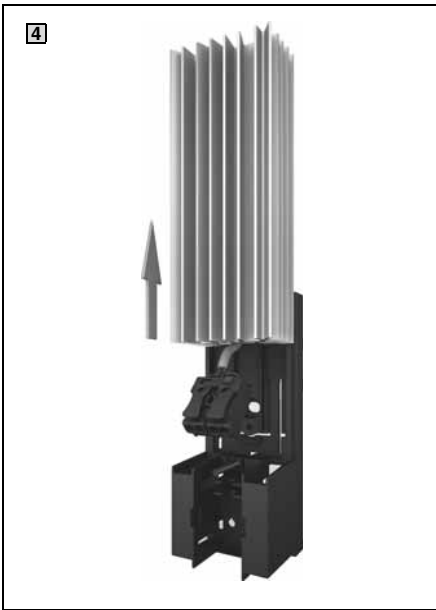
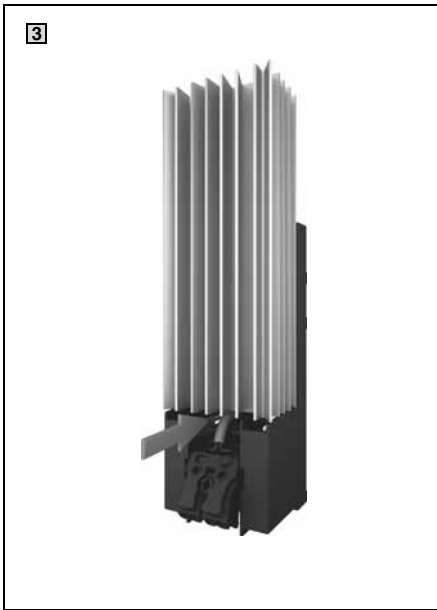
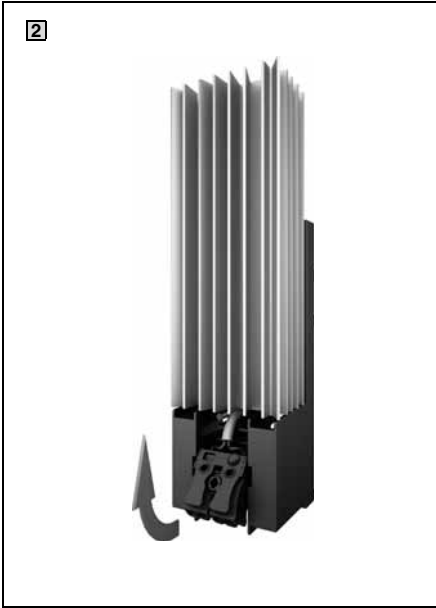

Fig. 4: Removal of the units

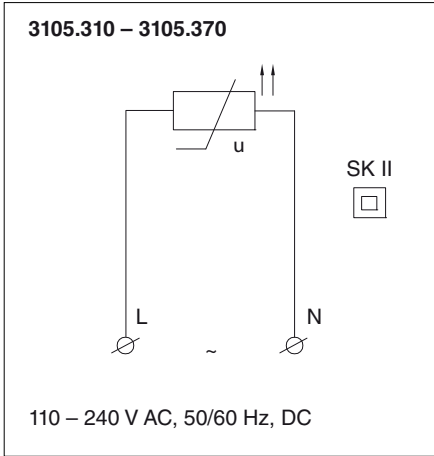

Fig. 5: Wiring plan – Heater

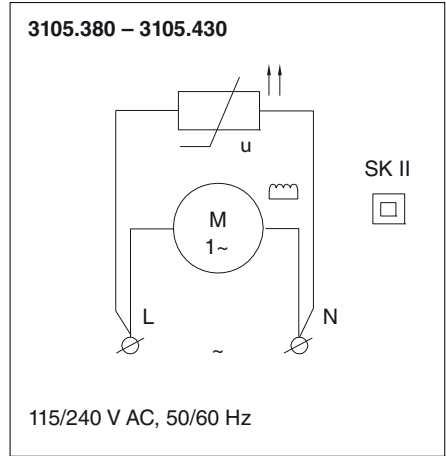

Fig. 6: Wiring plan – Heater with fan

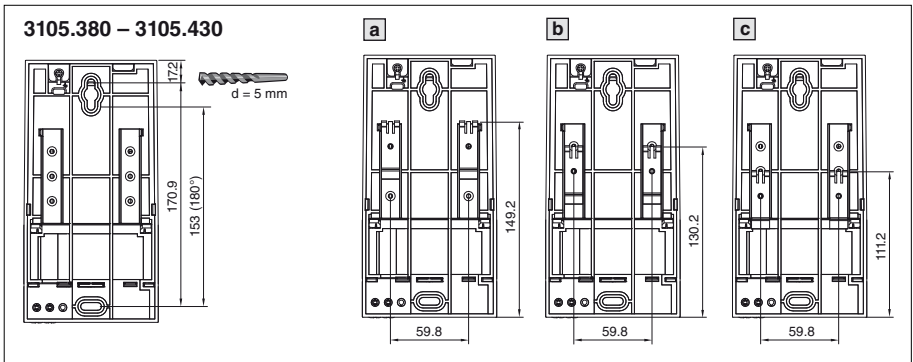

Fig. 7: Fastening onto a mounting plate/Fastening possibilities on support rails

9 Dimensions

EN

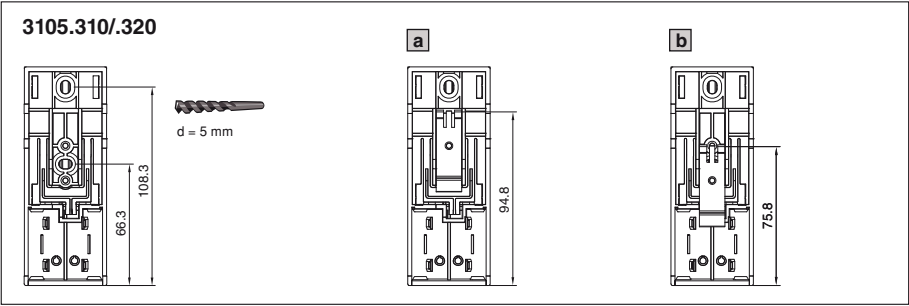

Fig. 8: Fastening onto a mounting plate/Fastening possibilities on support rails

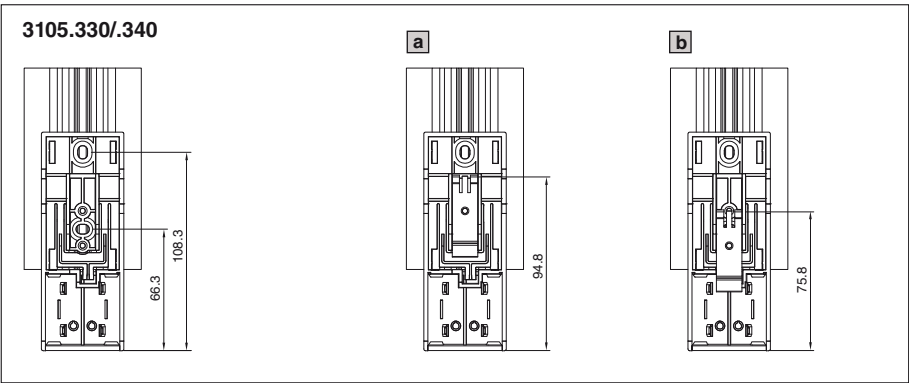

Fig. 9: Fastening onto a mounting plate/Fastening possibilities on support rails

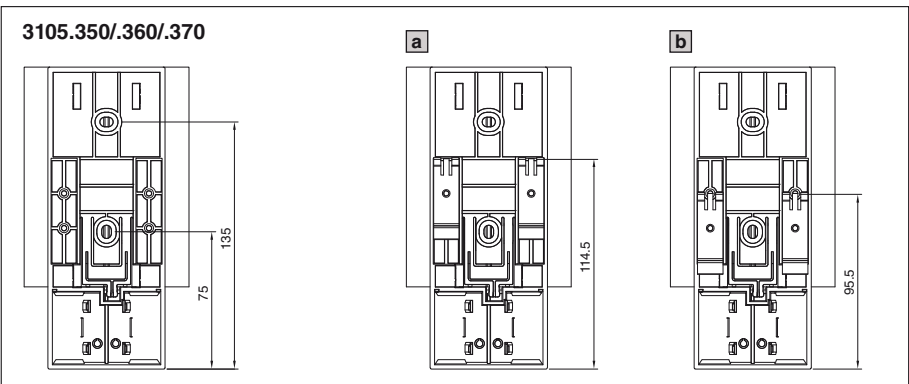

Fig. 10: Fastening onto a mounting plate/Fastening possibilities on support rails

Rittal – The System.

Faster – better – everywhere.

- Enclosures
- Power Distribution
- Climate Control
- IT Infrastructure
- Software & Services

RITTAL GmbH & Co. KG
Postfach 1662 • D-35726 Herborn
Phone +49(0)2772 505-0 • Fax +49(0)2772 505-2319
E-mail: info@rittal.de • www.rittal.com

ENCLOSURES

POWER DISTRIBUTION

CLIMATE CONTROL

IT INFRASTRUCTURE

SOFTWARE & SERVICES



FRIEDHELM LOH GROUP